

SC15FZW Motorised Foldable Monitors

FOLDABLE MONITOR

With its motorised foldable design, the monitor gives users flexible screen view angle which can have the position angle of the screen set between 100 to 180 degrees.

OPTIONAL TOUCH SCREEN ABILITY

It also offers touch screen ability as option if users want to free from using a mouse and keyboard.



Overview

The SC15FZW is the Motorised Foldable Monitor designed by SEADA to offer solutions for the Conference room, Office, Hotel, School, Control centre, Institutions, Auditorium and Reception with its elegant, stylish, and multi-functional design. The unit can be folded completely flat to the surface of the desk automatically with screen facing up or any degree between 100 to 180 to offer the best screen view angle to users.

The SC15FZW coming with powder coated and anodised finish provides a soft, silky effect and comes in black or silver finish for customers to choose from.

The standalone SC15FZW unit also has the ability to form a large paperless conference room system with more SC15FZW units or other SEADA conference products. This can be achieved by using the SEADA multimedia conference server.

Solutions that work for your meeting and conference room

SC15FZW MOTORISED FOLDABLE MONITORS

From SEADA

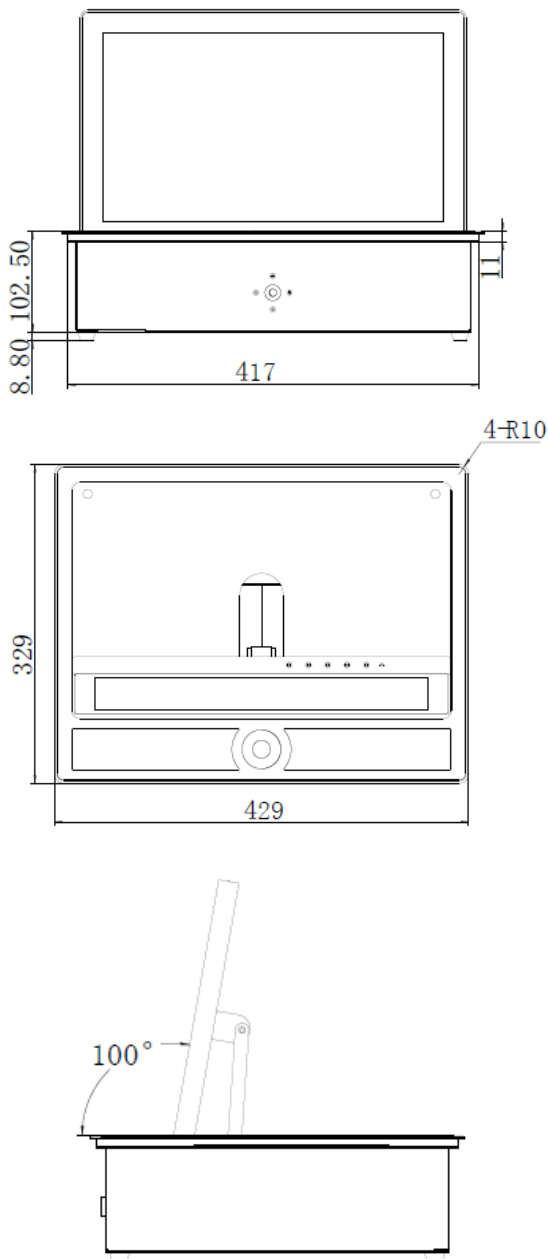

Model	SC15FZW
Screen Position Angle	100-180°
Screen Size (inches)	15.6
Touch Screen	Optional
Frame Finish	Anodised Aluminium
Display Resolution	1920x1080
Monitor Thickness	20mm
Aspect Ratio	16:9
Contrast	700:1
Brightness	300
Video Signal	HDMI/VGA
System Desktop Frame Size	429mm*329mm*3mm*4-R10
Housing Desktop Cut Size	419mm*319mm
Operating Temperature Range	0~40°
Operating Humidity Range	10%~90% non-condensing
Storage Temperature Range	-20~60°
Storage Humidity Range	10%~90% non-condensing
Parts Warranty	2 Years

SEADA CONFERENCE
Oak Tree Park
Burnt Meadow Road
Moons Moat North Industrial Estate, Redditch,
Worcestershire, UK, B98 9NW
www.seada.co.uk
Email: sales@seada.co.uk
Phone: +44 (0)1527 584364
Fax: +44 (0)1527 962998